

MODEL PG-2 PRESSURE GAUGE PRODUCT MANUAL

Thank you very much for choosing the Yoshitake's product. To ensure the correct and safe use of the product, please read this manual before use. This manual shall be kept with care for future references. The symbols used in this manual have the following meanings.



	Warning	This symbol indicates a potentially hazardous situation that, if not avoided, could result in death or serious injury.
	Caution	This symbol indicates a hazardous situation that, if not avoided, may result in minor or moderate injury or may result in only property damage.

Table of Contents

1. Specification	1
1.1 Specification	1
1.2 Accuracy of pressure gauge (allowable tolerance)	1
2. Structure, Dimensions and Weights	2
3. Delivery, Storage and Installation	2
3.1 Caution for delivery and storage.....	2
3.2 Warning and caution for installation	2-3
4. Operation	4
4.1 Warning and caution for use.....	4
5. Maintenance and Inspection	4
5.1 Troubleshooting.....	4
5.2 Warning and caution for maintenance and inspection ·	5
Warranty information	

YOSHITAKE

1. Specification

1.1 Specification

Model		PG-2
Application		Steam, gas, liquid *1
Maximum temperature		60°C *2
Largeness		φ100
Case shape		Type A
Pressure range		0 to 0.25 / 0.4 / 0.6 / 1.0 / 1.6 / 2.5 / 4.0 MPa 0 to 2.5 / 4.0 / 6.0 / 10 / 16 / 25 / 40 bar (Dual scale dial indicates pressure in bar and psi.)
Material	Case	SUS
	Bourdon tube	SUS
	Spanner flats	SUS
Connection		G3/8, BSPT1/2, NPT1/2

*1 If using oxygen, degrease treatment is needed. If using oxygen, please contact us.

*2 If application exceeds maximum temperature, use the product with siphon pipe.

*3 The product cannot be adjusted or disassembled.

*4 Please keep the product from water and use it in a dry place

1.2 Accuracy of pressure gauge (acceptable tolerance)

Scale range is according to Fig. 1.

(%)	
Scale range A	Scale range B
±1.6	±2.4

*Value of acceptable tolerance is expressed in percentage of pressure span (all scale range).

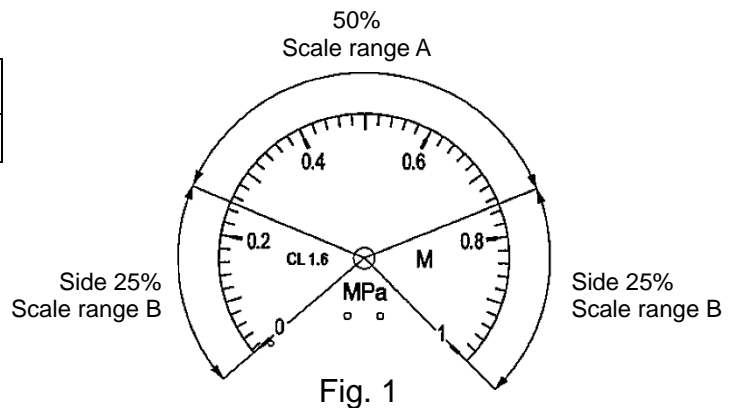

Fig. 1



Caution

Please confirm that the indications on the product correspond with the specifications of the ordered product model before use.

* If they are different, do not use the product and contact us.

2. Structure, Dimensions and Weights

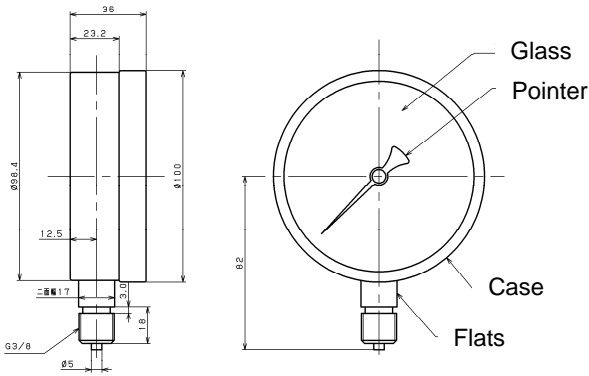

Width across flats 17

Fig.2 : Dimensions of the product with screw connection G3/8

*Weights are 0.31kg

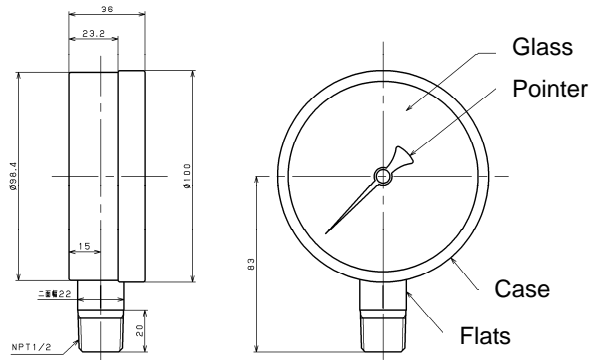

Width across flats 22

Fig.3 : Dimensions of the product with screw connection BSPT1/2-NPT1/2

*Weights are 0.38kg

3. Delivery, Storage and Installation

3.1 Caution for delivery and storage

⚠ Caution

1. During delivery, avoid addition of vibration to the product as possible. Be sure to avoid hitting the product on the wall and dropping the product.
*Failure to follow this notice may make the product unusable.
2. Store the product on the place where there are few dust, vibration, humidity. Also, select a place with less temperature change as possible because the product can form dew in a place with large temperature change.

3.2 Warning and caution for installation

⚠ Warning

1. If the product is used on a line with high frequency of pressure fluctuation, it will cause the product malfunction. Please take measures before applying pressure fluctuation directly to the pressure gauge.



Caution

1. Install the product so that scale plate is vertical.
* If not vertical, accidental error can be made.
2. In case of liquid measurement, if there is head difference between pressure pick-up port and pressure gauge, accuracy is influenced. For example, to measure water pressure, if installing pressure gauge of pressure range 0 to 0.1 MPa on the place of 1 m higher than pressure pick-up port, reading is the value of actual pressure minus 0.01 MPa. This difference is equivalent to 10% of all scale range (Fig. 4). Conversely, if installing pressure gauge of pressure range 0 to 0.1 MPa on the place of 1 m lower than pressure pick-up port, reading is the value of actual pressure plus 10% (Fig. 5).

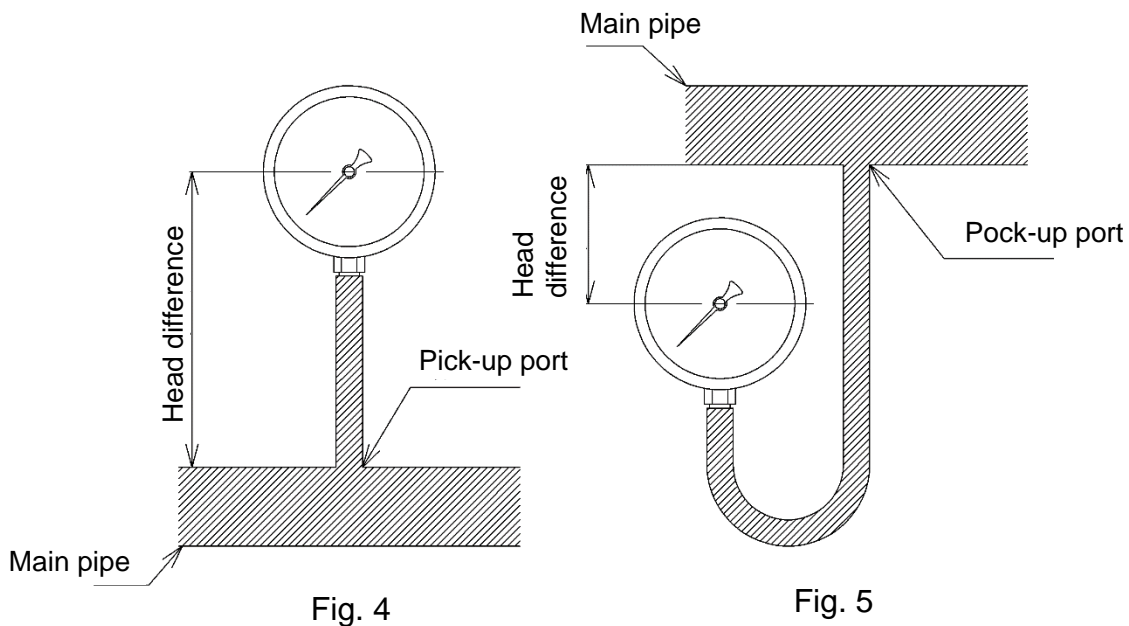

3. Avoid using the product at place where it is exposed to high temperature. If necessary, prevent the product from being exposed to heat directly by using closure plate, etc.
4. If application exceeds maximum temperature, install siphon tube to reduce fluid temperature.
5. Avoid using the product at place where much vibration occurs.
6. If fluid has pulsation, use dampener to install the product. To adjust dampener, close it fully at once, then adjust it by opening little by little. In this case, do not tighten the product enough to stop pointer swinging completely. Adjust to the extent that pointer swing remains slightly.
7. To install the product, be sure to apply appropriate tool such as spanner to hexagonal part and tighten it. Be sure to avoid screwing the product with holding the product case.
8. Before installing the product, be sure to remove foreign substances and scale from the piping. During installation, prevent foreign substances flowing into the piping, such as packing, seal tape, liquid seal agent, etc.
* Commingling of foreign substance or scale into the product prevents the product from functioning properly.

4. Operation

4.1 Warning and caution for use

Warning

1. Do not apply pressure more than maximum pressure to the product.
* If bourdon tube is broken, it may lead to injury or damage to the surroundings.
2. Use the product within usable temperature range.
* If using the product out of usable temperature range, the product may be broken and lead to injury of damage to the surroundings
3. Do not use the product for the fluid with corrosive property for the wetted part material of the product.
* If bourdon tube is broken due to corrosion, it may lead to human injury or damages to the surroundings.

Caution

1. Make using pressure be in the range of 25 – 75 % of maximum scale.
2. Do not disassemble the product.
* It will cause product malfunction.

5. Maintenance and inspection

5.1 Troubleshooting

Trouble	Cause	Remedy
Pointer does not work.	1. Pressure is not applied	1. Apply pressure.
	2. Piping is clogged by foreign substance.	2. Remove foreign substance.
Accidental error is large.	1. Fluid exceeds usable temperature range.	1. Lower temperature.
	2. Head difference due to difference of height.	2. Correct the head.
	3. Abrasion of internal structure due to heavy vibration or pressure fluctuation.	3. Replace with new one.
Response is slow.	1. Too much tightening of dampener.	1. Make appropriate tightening.
	2. Piping is too thin for viscosity of fluid.	2. Make the piping thick.
Pointer does not point zero when the product is removed from piping.	1. Deformation of bourdon tube due to over pressure.	1. Replace with new one.
	2. Clogging of foreign substance in fluid.	2. Remove foreign substance.
	3. Abrasion of internal structure due to heavy vibration or pressure fluctuation.	3. Replace with new one.
Off the scale	1. Deformation of bourdon tube due to over pressure.	1. Replace with new one.
	2. Gap of pointer and deformation of bourdon tube due to impact.	2. Replace with new one.

5.2 Warning and caution for maintenance and inspection

Warning

1. To remove the product, be sure to make pressure zero (atmospheric pressure) and then remove the product carefully.
* Failure to follow this notice may make blowout of internal fluid and lead to scalds or injury.
2. If fluid is in high temperature, do not touch the product directly with bare hands.
* Failure to follow this notice may lead to scalds or injury.
3. If glass crack or deterioration is found, be sure to replace the product with new one.

Caution

1. Regardless of regulation by law, conduct maintenance and inspection once or more per year periodically.
* Remove the product from the site and check it with pressure standards.
2. The product cannot be repaired or calibrated. If abnormality is found, replace the product with new one.