

## About Drain Separator

### What is a Drain Separator ??

In a steam/air piping system, drain (water) causes problems, such as rust and water hammer. It also decreases the dryness and heat quantity content of steam and thermal efficiency in a steam system. The DS-1 and DS-2 are separators making use of centrifugal force and impact force to effectively separate drain inside piping.

### ■ Problems related to existence of drain in the piping system

Failure to properly handle drain in steam piping and air/gas systems results in various problems.

#### Case 1: Declined thermal efficiency

Drain in a steam system reduces the effective heat quantity (latent heat) in addition to the dryness of steam. In some situations, drain exposes an excessive load on a steam trap, making the discharge capacity insufficient. It also forms water film on the heating surface of the system, which prevents thermal conduction and reduces the system's efficiency.

Additionally, the water directly carried over from a boiler (hot water before evaporation) contains a lot of impurities, and part of them form scale that blocks thermal conduction on the heating surface.

#### Case 2: Outbreak of water hammer

Water is higher than steam in density and slows its velocity inside piping because of its characteristics. However, drain inside steam piping is carried by steam flowing at high velocity and may give a strong vibration or load to a valve or controlling unit when drain strikes against it. This is called water hammer and causes damage to or wear (erosion) in units.

#### Case 3: Formation of scale

In general, carbon steel pipes for piping are widely used for steam piping. When drain or another liquid contacts them, rust forms. It is quite likely that pressure reducing valves and other control units will malfunction due to scale, including rust.

#### Case 4: Drain problems in air / gas systems

Piping or valve corrosion attributable to drain causes a strainer or trap to clog, and cleaning by air blowing sometimes increases contamination against expectations.

### Guidelines for Drain Separator

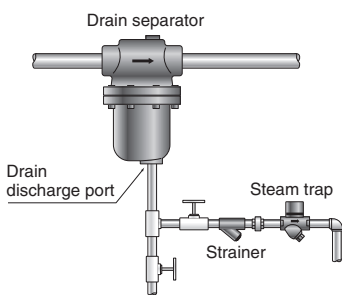

- Connect the drain separator horizontally to piping with the drain discharge port down.
- Place a trap under the drain discharge port.
- Set the top of the trap lower than the drain discharge port of the drain separator.

- Check the flowing direction of the fluid and the inlet and outlet directions of the drain separator in advance, and properly install it.
- This product is heavy. When connecting it to piping, securely support the product and the piping with a lifting device.
- When installing the product, secure the space of the dimension H<sub>3</sub> shown in the figure below, which is required for maintenance and inspections.

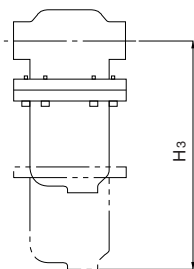

Nominal size	H <sub>3</sub>
15A	210
20A	210
25A	210
32A	240
40A	240
50A	290
65A	350
80A	410
100A	550

### Nominal Size Selection Table

- Drain separator causes almost no pressure loss, so select the same size as piping size.

#### ●SPG piping v = 30 m/s Saturated steam (kg/h)

Nominal size Pressure (MPa)	15A	20A	25A	32A	40A	50A	65A	80A	100A
0.05	18	33	55	92	125	202	334	471	803
0.1	24	44	72	120	164	265	437	617	1051
0.2	35	64	105	176	240	388	639	903	1538
0.3	47	84	138	231	314	508	837	1183	2015
0.4	58	104	170	285	387	627	1033	1460	2485
0.5	69	124	202	339	460	745	1227	1734	2952
0.6	79	143	234	392	533	862	1420	2006	3415
0.7	90	163	266	445	605	978	1611	2276	3876
0.8	101	182	297	498	676	1094	1802	2546	4335
0.9	112	201	329	551	748	1209	1993	2815	4793
1.0	122	220	360	603	819	1325	2183	3083	5250
1.1	133	240	392	655	890	1440	2372	3351	5707
1.2	144	259	423	708	961	1555	2562	3619	6162
1.3	154	278	454	760	1033	1670	2752	3887	6618
1.4	165	297	486	813	1104	1785	2941	4155	7074
1.5	176	316	517	865	1175	1900	3131	4422	7530
1.6	186	336	548	917	1246	2015	3320	4690	7986
1.7	197	355	580	970	1317	2130	3510	4958	8442
1.8	208	374	611	1022	1389	2246	3700	5227	8899
1.9	218	393	642	1075	1460	2361	3890	5496	9357
2.0	229	413	674	1128	1532	2477	4081	5765	9816

## Features of drain separator

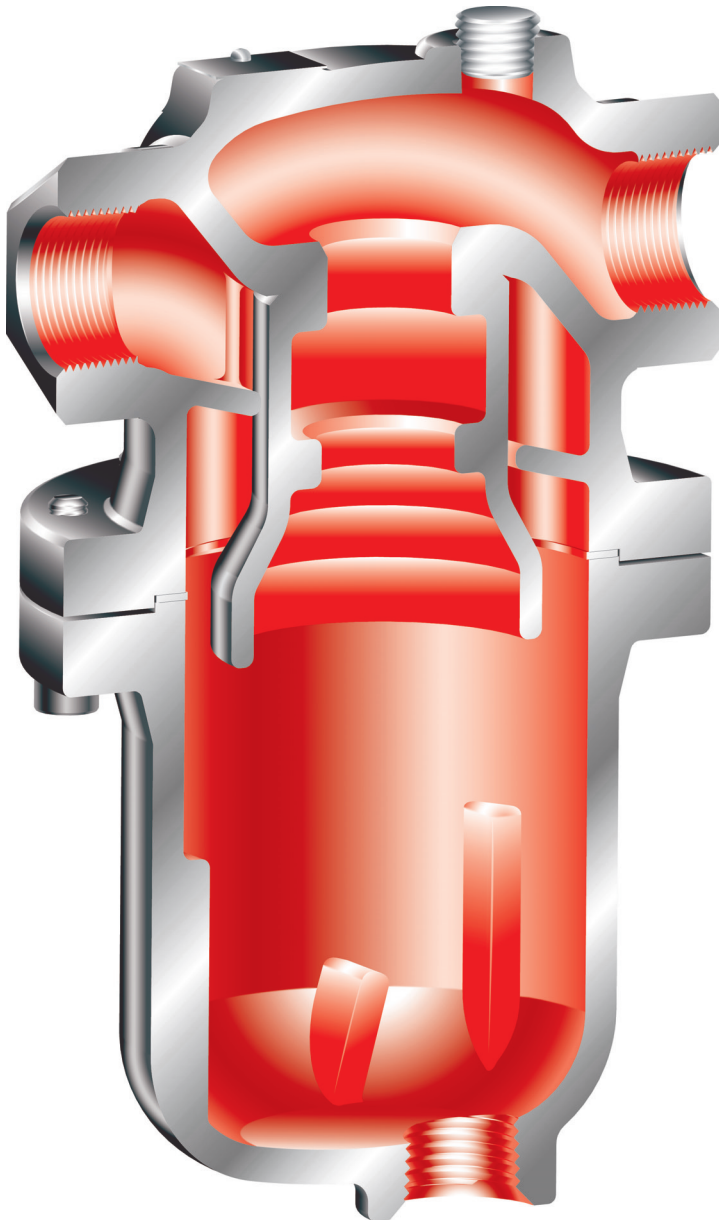

### 1: High separating efficiency

As soon as steam or air flows into the drain separator, centrifugal force starts to work by the internal structure of the body. Drain swirls along the wall surface in consequence of the difference in specific gravity between it and the steam or air, and strikes against the baffle. The drain is then guided to discharge port and released by the installed trap.

### 2: No pressure loss

Size of separator can be the same as piping size. Since sectional area of inside separator is larger than piping size, pressure loss is considered as zero.

### 3: Advantages

- **Improve dryness of steam**

The water content of the steam will lead to have heat loss. The more dried steam gets more useful heat energy.

- **Prevent problem associated with contained water or air**

Water in steam or air may cause erosion on valve, valve seat and fittings due to high velocity water, and valve or piping system may fail because of rapid wear or water hammer.

- **Supply less wet compressed air**

The air compressed by compressor will be cooled at piping, cooler, or receiver tank, etc. Such resulting wetness in the air may cause corrosion in piping line and less durability of the piping system.

- **Maintenance-free**

Since no movable parts are used inside, the drain separator is maintenance-free (except the aging of the gasket).

## DS-1·2

Drain (condensate) in steam and air piping causes a decline in thermal efficiency, water hammer, corrosion of devices, valves, and pipes, and many other problems.

The DS-1 and DS-2 drain separators are capable of efficiently separating condensate from steam and air with the aid of centrifugal force generated from the configuration of the passage. In normal condition, use a separator of the same size as piping for both steam and compressed air systems.

### Features

1. High efficient drain separation due to cyclone type.
2. Extremely low pressure loss.
3. Trouble-free by minimizing the number of moving parts.

### Specifications

Model	DS-1	DS-2
Application	Steam, Air	
Maximum pressure	2.0 MPa (1.0 MPa for air)	
Maximum temperature	220°C	
Material	Body	Ductile cast iron
	Nozzle	Cast iron
	Receiver	Ductile cast iron
Connection	JIS Rc screwed	JIS 10K/20K FF flanged

### Dimensions (mm) and Weights (kg)

Model	Nominal size	d	L	H	H <sub>1</sub>	d <sub>0</sub>	Weight
DS-1	15A	Rc 1/2	150	243	193	Rc 3/4	7.1
	20A	Rc 3/4	150	243	193	Rc 3/4	7.1
	25A	Rc 1	150	243	193	Rc 3/4	7.3
	32A	Rc 1-1/4	190	282	213	Rc 1	12.5
	40A	Rc 1-1/2	190	282	213	Rc 1	12.5
	50A	Rc 2	219	342	260	Rc 1	20.5
DS-2	15A	—	174 (178)	243	193	Rc 3/4	8.5 (8.7)
	20A	—	204 (208)	243	193	Rc 3/4	9.6 (9.8)
	25A	—	204 (208)	243	193	Rc 3/4	10.1 (10.5)
	32A	—	222 (226)	282	213	Rc 1	15.6 (16.0)
	40A	—	242 (246)	282	213	Rc 1	16.3 (16.7)
	50A	—	246 (250)	342	260	Rc 1	24.7 (24.9)
	65A	—	288 (292)	418	314	Rc 1	40.0
	80A	—	335 (343)	484	361	Rc 1-1/4	56.0
100A	—	390 (402)	594	445	Rc 1-1/4	100.0	

• The above values in parentheses are the dimensions and weights of JIS 20K FF flanged.



DS-1



DS-2

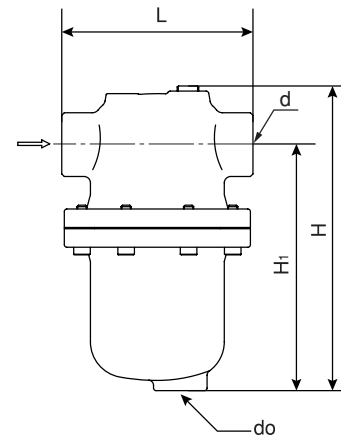

DS-1

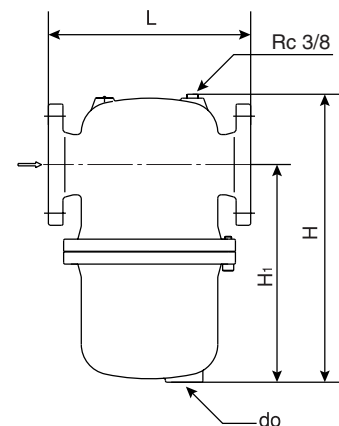

DS-2

## Selecting a Nominal Size

Keep the instruction described below in mind to enable the drain separator to operate most effectively and meet working conditions to the fullest extent possible.

### ● Selecting a drain separator nominal size

Select the same nominal size as that of piping (nominal size of piping = nominal size of drain separator). Using a drain separator of a smaller nominal size may increase pressure loss, resulting in failure to keep the specified pressure at the outlet of a unit.

**Table 1: Working flow velocity**

Application	Flow velocity
Steam	30 m/sec or less
Air	15 m/sec or less

- Keep the fluid below the specified flow velocity.
- A higher flow velocity may cause drain separation to fail.

## Nominal Size Selection Table

Drain separator causes almost no pressure loss, so select the same size as piping size.

### ● SPG piping $v = 30$ m/s Saturated steam

(kg/h)

Nominal size Pressure (MPa)	15A	20A	25A	32A	40A	50A	65A	80A	100A
0.05	18	33	55	92	125	202	334	471	803
0.1	24	44	72	120	164	265	437	617	1051
0.2	35	64	105	176	240	388	639	903	1538
0.3	47	84	138	231	314	508	837	1183	2015
0.4	58	104	170	285	387	627	1033	1460	2485
0.5	69	124	202	339	460	745	1227	1734	2952
0.6	79	143	234	392	533	862	1420	2006	3415
0.7	90	163	266	445	605	978	1611	2276	3876
0.8	101	182	297	498	676	1094	1802	2546	4335
0.9	112	201	329	551	748	1209	1993	2815	4793
1.0	122	220	360	603	819	1325	2183	3083	5250
1.1	133	240	392	655	890	1440	2372	3351	5707
1.2	144	259	423	708	961	1555	2562	3619	6162
1.3	154	278	454	760	1033	1670	2752	3887	6618
1.4	165	297	486	813	1104	1785	2941	4155	7074
1.5	176	316	517	865	1175	1900	3131	4422	7530
1.6	186	336	548	917	1246	2015	3320	4690	7986
1.7	197	355	580	970	1317	2130	3510	4958	8442
1.8	208	374	611	1022	1389	2246	3700	5227	8899
1.9	218	393	642	1075	1460	2361	3890	5496	9357
2.0	229	413	674	1128	1532	2477	4081	5765	9816