

20K Gate Valve

20SLBO
B.B.O.S.Y.
RF-flanged

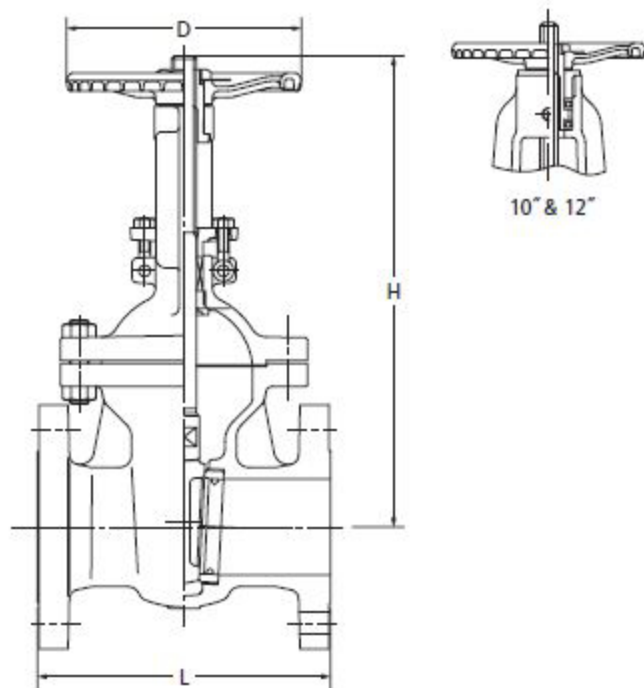

F-F dimension : JIS B 2002
End flanges: JIS B 2239 20K

120°C Static water..... 2.75MPa
220°C Steam, air, gas, oil..... 2.45MPa
300°C Steam, air, gas, oil..... 2.26MPa
350°C Steam, air, gas, oil..... 1.96MPa

● Use for lubricating or hydraulic oil is acceptable.

Materials

Parts	JIS material
Body	FCD-S
Bonnet	FCD-S
Stem	SUS 403
Disc	SUS 403 (8"~12": SCPH2+13Cr)
Body seat ring	SUS 403 (1½": SCS 1)
Gland	FCD-S
Gland packing	Asbestos-free
Handwheel	FCD 400
Wheel nut	SS 400
Bonnet bolt/nut	S45C
Gland bolt/nut	SS 400
Yoke sleeve	C6782BE (6"~12": HBSc2)
Gasket	Asbestos-free
Name plate	A1050P

Dimensions

Size	mm										
	mm inch	40	50	65	80	100	125	150	200	250	300
L		190	216	241	283	305	381	403	419	457	502
H (open)		326	395	450	520	595	725	820	1070	1247	1451
D		160	200	200	250	250	300	350	400	450	500

NOTE : For flange dimensions refer to Page 40.